

Bracke M36.b

Three-row moulder

The Bracke M36.b is a three-row moulder that attaches to a large prime mover and is suitable for both small and large scarification sites. Thanks to its flexibility, the Bracke M36.b provides very good results on all kinds of mounding sites.

Design

The arms of the Bracke M36.b are articulated so that they give way to fixed obstacles. The outer arms have adjustable intermediate widths. To adapt to various soil conditions, Bracke M36.b can be delivered with three- or four-pointed mattock wheels. The hydraulics are load-sensing and are connected to the prime mover. Central lubrication is standard on the Bracke M36.b.

Mattock wheel

The design of the mattock wheel combined with easily replaceable tooth plates provides very good results on the planting mounds. The design of the tooth plate allows the edge to maintain its sharpness in operation and the results on the mounds are kept optimal throughout the life of the plate.

Machine control

Bracke Growth Control, the control system, is based on a PLC platform and communicates over a CAN bus. With the new display, the control system is very user friendly. The moulder is fitted with sensors that send information to Bracke Growth Control about, for example, the prime mover's speed and the rate of rotation of the mattock wheels. The control system has eight programmable operating programs chosen from the controls in the cab. The display is used to make settings in the control system and read information from the scarifier. Bracke Growth Control keeps track of the number of mounds, for both individual sites and in total, the distance covered, and the number of hours worked.

Scarification

The operator controls the Bracke M36.b from the cab using the Bracke Growth Control. Depending on changes in the site conditions, one of the preset programs are chosen. The mattock wheels are hydraulically controlled and their rate of rotation is geared to the machine's speed and the chosen operating program. Bracke Growth Control enables the operator to set the Bracke M36.b to make mounds or scarify patches of varying lengths, depending on what the surroundings require. The arms can be controlled independently of each other so that they can be run as one or two rows when necessary.

Bracke reserves the right to make changes. 2017-06-25

Technical data

Prime mover	Forwarder/skidder 16-20 ton
Weight	5,200 kg
Mattock wheels	Choice of three- or four-pointed
Mattock wheel radius	725 mm
Hydraulic pressure	160 bar
Hydraulic flow	90 l/min
Electrical system	24V
Control system	
Bracke Growth Control	PLC based
Accessories	Seeder S35.a

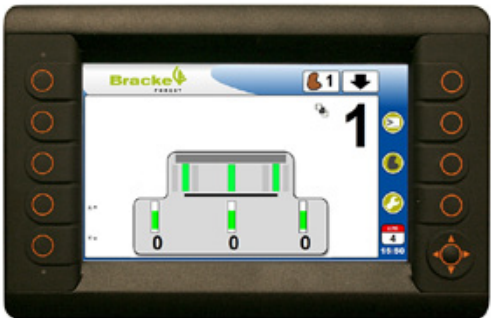

Bracke Growth Control is a PLC-based control system.

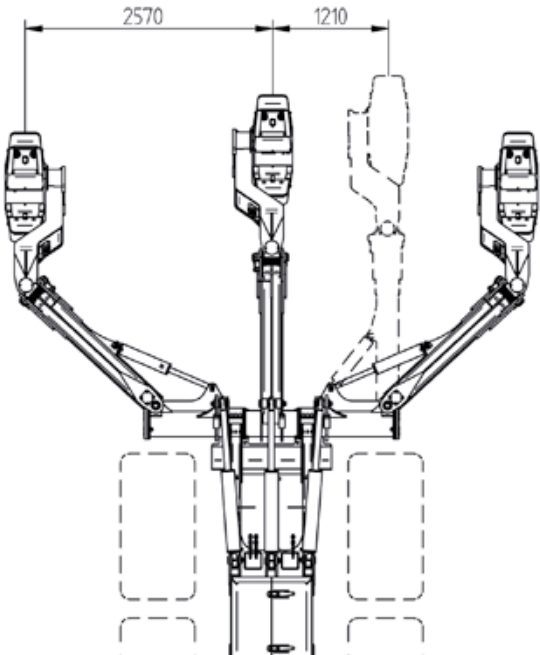
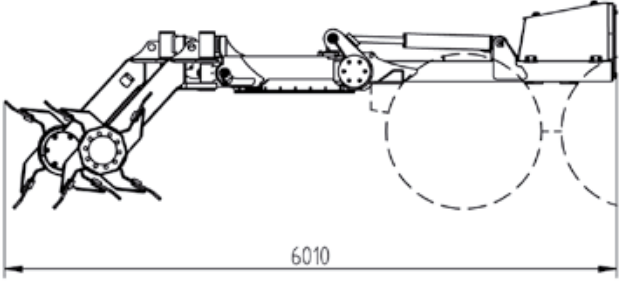

Scarification with the M36.b gives plants and seeds the best possible start for growth and survival whatever the terrain.



Planting in inverted humus after the M36.b provides good conditions for high production.

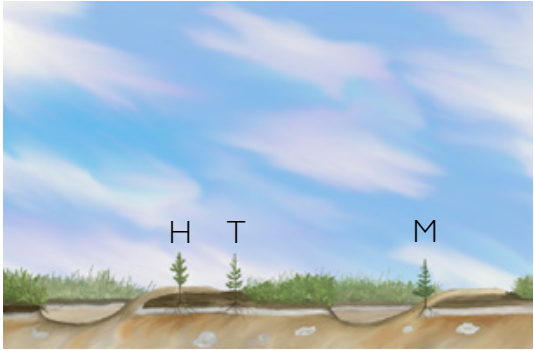

The Bracke M36.b creates planting spots with inverted humus (T), mineral soil mounds on inverted humus (H), and mineral soil mounds (M).

Bracke reserves the right to make changes. 2017-06-25

SILVANA IMPORT TRADING INC.
 4269 St. Catherine West, Suite 304, Montreal, Quebec Canada H3Z 1P7
 Toll Free: 1 888 939-3523 Phone: 1 514 939-3523 Fax: 1 514 939-3863
 info@silvanatrading.com www.silvanatrading.com
 www.brackeforest.ca